

## SELLO MECANICO SP-5610 / 5620Q

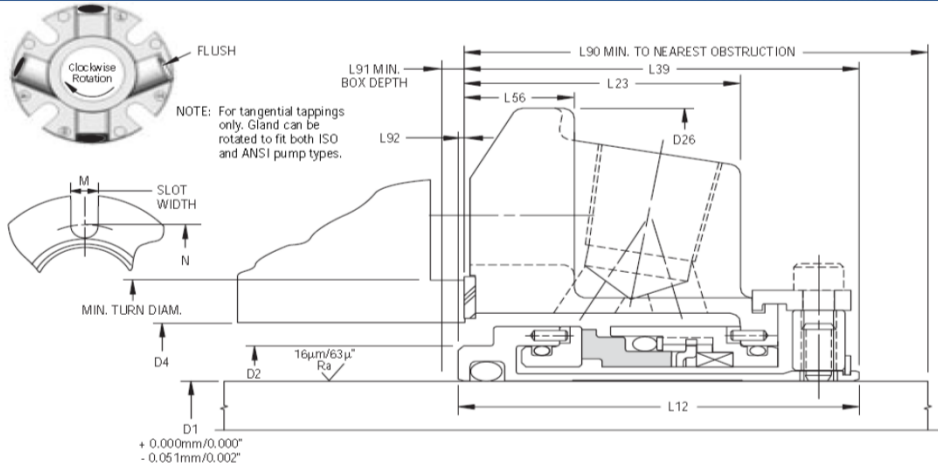

| D1<br>(pulgadas) | D2    | D4    |       | D26    | L12   | L23   | L39   | L56   | L90   | L91   | L92   | M     | N      |
|------------------|-------|-------|-------|--------|-------|-------|-------|-------|-------|-------|-------|-------|--------|
|                  |       | Min.  | Max.  |        |       |       |       |       |       |       |       |       |        |
| 1.000            | 1.375 | 1.445 | 1.889 | 4.000  | 1.989 | 1.353 | 1.954 | 0.531 | 2.000 | 0.16  | 0.035 | 0.525 | 2.805  |
| 1.125            | 1.500 | *     | 2.015 | 4.125  | 2.062 | 1.446 | 2.062 | 0.531 | 2.125 | 0.125 | *     | 0.525 | 2.933  |
| 1.250            | 1.625 | *     | 2.294 | 4.250  | 2.062 | 1.446 | 2.062 | 0.531 | 2.125 | 0.125 | *     | 0.525 | 3.213  |
| 1.375            | 1.750 | *     | 2.421 | 4.375  | 2.062 | 1.446 | 2.062 | 0.531 | 2.125 | 0.125 | *     | 0.525 | 3.338  |
| 1.500            | 1.937 | 2.007 | 2.680 | 4.875  | 2.156 | 1.487 | 2.125 | 0.593 | 2.187 | 0.156 | 0.031 | 0.525 | 3.599  |
| 1.625            | 2.062 | 2.132 | 2.812 | 5.000  | 2.156 | 1.487 | 2.125 | 0.593 | 2.187 | 0.156 | 0.031 | 0.562 | 3.766  |
| 1.750            | 2.170 | 2.240 | 2.918 | 5.250  | 2.156 | 1.487 | 2.125 | 0.593 | 2.187 | 0.156 | 0.031 | 0.562 | 3.875  |
| 1.875            | 2.312 | 2.382 | 2.918 | 5.250  | 2.156 | 1.487 | 2.125 | 0.593 | 2.187 | 0.156 | 0.031 | 0.562 | 3.875  |
| 2.000            | 2.437 | 2.507 | 3.015 | 5.500  | 2.375 | 1.601 | 2.312 | 0.593 | 2.375 | 0.187 | 0.062 | 0.562 | 4.000  |
| 2.125            | 2.562 | 2.632 | 3.360 | 5.859  | 2.375 | 1.601 | 2.312 | 0.593 | 2.375 | 0.187 | 0.062 | 0.687 | 4.469  |
| 2.250            | 2.687 | 2.757 | 3.485 | 6.500  | 2.375 | 1.601 | 2.312 | 0.593 | 2.375 | 0.187 | 0.062 | 0.687 | 4.566  |
| 2.375            | 2.812 | 2.882 | 3.610 | 6.500  | 2.484 | 1.717 | 2.466 | 0.625 | 2.528 | 0.143 | 0.018 | 0.687 | 4.719  |
| 2.500            | 3.062 | *     | 3.891 | 6.750  | 2.484 | 1.717 | 2.562 | 0.625 | 2.625 | 0.125 | *     | 0.687 | 5.000  |
| 2.625            | 3.312 | *     | 4.062 | 6.750  | 2.500 | 1.625 | 2.500 | 0.625 | 2.562 | 0.125 | *     | 0.687 | 5.170  |
| 2.750            | 3.312 | *     | 4.062 | 6.750  | 2.500 | 1.625 | 2.500 | 0.625 | 2.562 | 0.125 | *     | 0.687 | 5.170  |
| 2.875            | 3.375 | *     | 4.186 | 7.000  | 2.500 | 1.725 | 2.500 | 0.625 | 2.562 | 0.125 | *     | 0.687 | 5.312  |
| 3.000            | 3.625 | *     | 4.469 | 7.750  | 2.500 | 1.787 | 2.562 | 0.625 | 2.625 | 0.125 | *     | 0.812 | 5.720  |
| 3.125            | 3.750 | 3.853 | 4.600 | 7.875  | 2.562 | 1.593 | 2.562 | **    | 2.687 | 0.125 | *     | 0.812 | 5.845  |
| 3.250            | 3.750 | 3.853 | 4.600 | 7.437  | 2.562 | 1.593 | 2.510 | **    | 2.635 | 0.177 | 0.062 | 0.812 | 5.845  |
| 3.375            | 4.000 | 4.125 | 4.850 | 8.125  | 2.562 | 1.593 | 2.562 | **    | 2.687 | 0.125 | *     | 0.812 | 6.095  |
| 3.500            | 4.125 | 4.25  | 4.975 | 8.250  | 2.562 | 1.593 | 2.562 | **    | 2.687 | 0.125 | *     | 0.812 | 6.220  |
| 3.625            | 4.218 | 4.343 | 5.100 | 8.375  | 2.562 | 1.593 | 2.562 | **    | 2.687 | 0.125 | *     | 0.687 | 6.250  |
| 3.750            | 4.343 | 4.468 | 5.199 | 8.750  | 2.562 | 1.593 | 2.562 | **    | 2.687 | 0.125 | *     | 0.687 | 6.770  |
| 3.875            | 4.468 | 4.593 | 5.375 | 8.750  | 2.562 | 1.593 | 2.562 | **    | 2.687 | 0.125 | *     | 0.812 | 6.636  |
| 4.000            | 4.593 | 4.718 | 5.500 | 9.000  | 2.562 | 1.593 | 2.562 | **    | 2.687 | 0.125 | *     | 0.812 | 6.761  |
| 4.125            | 4.718 | 4.843 | 5.625 | 9.000  | 2.562 | 1.593 | 2.562 | **    | 2.687 | 0.125 | *     | 0.812 | 6.886  |
| 4.250            | 4.843 | 4.968 | 5.750 | 9.250  | 2.562 | 1.593 | 2.562 | **    | 2.687 | 0.125 | *     | 0.812 | 7.011  |
| 4.500            | 5.093 | 5.218 | 6.000 | 9.500  | 2.562 | 1.593 | 2.562 | **    | 2.687 | 0.125 | *     | 0.812 | 7.261  |
| 4.750            | 5.343 | 5.468 | 6.313 | 10.375 | 2.562 | 1.593 | 2.562 | **    | 2.687 | 0.125 | *     | 0.812 | 7.574  |
| 5.000            | 5.843 | 5.968 | 7.260 | 12.000 | 2.953 | 1.749 | 3.043 | **    | 3.168 | 0.125 | *     | 0.812 | 10.000 |
| 5.250            | 6.093 | 6.218 | 7.510 | 12.250 | 2.953 | 1.749 | 3.043 | **    | 3.168 | 0.125 | *     | 0.812 | 10.250 |
| 5.500            | 6.343 | 6.468 | 8.000 | 12.687 | 2.953 | 1.749 | 3.043 | **    | 3.168 | 0.125 | *     | 0.937 | 10.500 |

\* No es aplicable. Totalmente fuera montado.

\*\* No aplicable. Consulte la L23 para tamaños de más de 3"

### DESCRIPCION DEL PRODUCTO

Es un sistema modular encartuchado para una fácil instalación y mantenimiento, incluye juntas tóricas como elementos de sellado secundarios, es un sello de empuje. Se le puede incorporar a la brida una conexión para proporcionar mejor enfriamiento, convirtiéndose este en 5610Q. Son reversibles ya que sus caras de contacto se pueden intercambiar, para permitir girar el asiento o la cara rotativa de sellado. Se adapta a la norma ANSI B73.1M, 3069 ISO y DIN 24960

### CONDICIONES DE OPERACION

- \* **Temperatura:** -30°C a +205°C / -20°F a +400°F.
- \* **Presiones:** Hasta 75 mm (3") 21 bar g/300 psig max.  
Mas de 75mm (3") 13 bar g/200 psig max.
- \* **Velocidad:** 25 m/s 5000 fpm

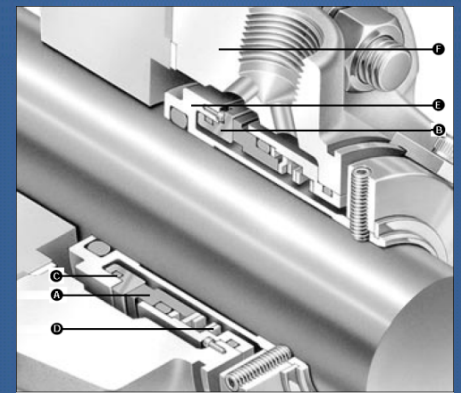

- A - Cara Primaria
- B - Cara de acoplamiento
- C - Empaque Secundaria ORing
- D - Resorte de carga ondulado
- E - Manga
- F - Brida tipo Quench

## Ventas y Centros de Servicio

**Sucursal Metropolitana**  
Calz. Vallejo 489 Esq. Cuiclahuac, Mex. DF.  
Tel.: (55) 5355 6906, 5355 4605

**Sucursal del Bajío**  
Madroño No. 430. San Luis Potosí, SLP.  
Tel.: (444) 2980 865, (55) 4330 5551

**Sucursal Oriente**  
Ignacio Allende No. 114-1 Puebla, Pue.  
Tel.: (222) 2331 583

**Sucursal Poniente**  
Bulvd. Miguel Alemán No. 107 Toluca.  
Tel.: (722) 2683 464 / 465

ventas@sellopac.com  
www.sellopac.com.mx